



**QMS 2560
Illustrated Parts
Manual**

July 1999

PREFACE

1. The part numbers listed in Parts Manual are those which were assigned to the parts making up the machine at the time machine was originally introduced onto the market.
2. Parts whose numbers are preceded by an asterisk in the Index Column on the List Page are parts to be used in only certain market areas. Therefore, please check the number in the Area column on the List Page and then compare it with the numbers given in the Area Chart on page II to find out which part number is applicable to your own Areas.
NOTE: Parts for only certain Market Areas: The part numbers for these parts vary according to market area. In other cases, these parts are used in only restricted areas.
3. The Index Number on the List Page is composed of two numbers and two letters. Generally, only A is used as the first letter of the two letters. However, sometimes B, C, D, etc. are used when one part in the illustration, such as an electrical parts or a part which varies according to market areas, has two or more part numbers. The second of the two letters represents the modification history of that part.
4. The Areas Number is listed in the Areas Column for only those parts used in certain market areas. This Area Number represents the areas listed opposite to it in the Chart given on Page II. Parts having no Area Number listed in the Area Column can be used in all market areas.
5. In the exploded views in this Parts Manual the parts (Screws & Washes, etc...) which are indicated with a "four-digit" numbers are listed in numerical order in the section "SCREWS AND WASHERS". Please check these "four-digit" numbers with the part numbers ("ten-digit" numbers) which should be used for ordering the part.
6. All part numbers consist of "ten-digit" which should all be quoted when ordering a part. The price of parts can be obtained by referring to the "Parts Price List" which is separately issued.
7. All information contained in this parts manual is subject to change.

AREA CHART

AREA No.	AREA	AREA No.	AREA
0400	METRIC		
2300	INCH		

We recommend that you cross out from your Parts Manuals those parts numbers which do not apply your area so that no error is made when ordering parts.

CONTENTS

1.	HOUSING	1
2.	FRAMES	3
3.	FUSING SECTION (A)	5
4.	FUSING SECTION (B)	7
5.	MANUAL FEED SECTION (OPTION)	9
6.	TRANSPORT SECTION	11
7.	ELECTRICAL COMPONENTS	13
8.	PAPER TAKE-UP SECTION	15
9.	DRIVE SECTION	17
10.	PAPER TRAY UNIT	19
11.	WIRING ACCESSORIES AND JIGS	21
12.	SCREWS AND WASHERS	23
13.	NUMERICAL INDEX	24

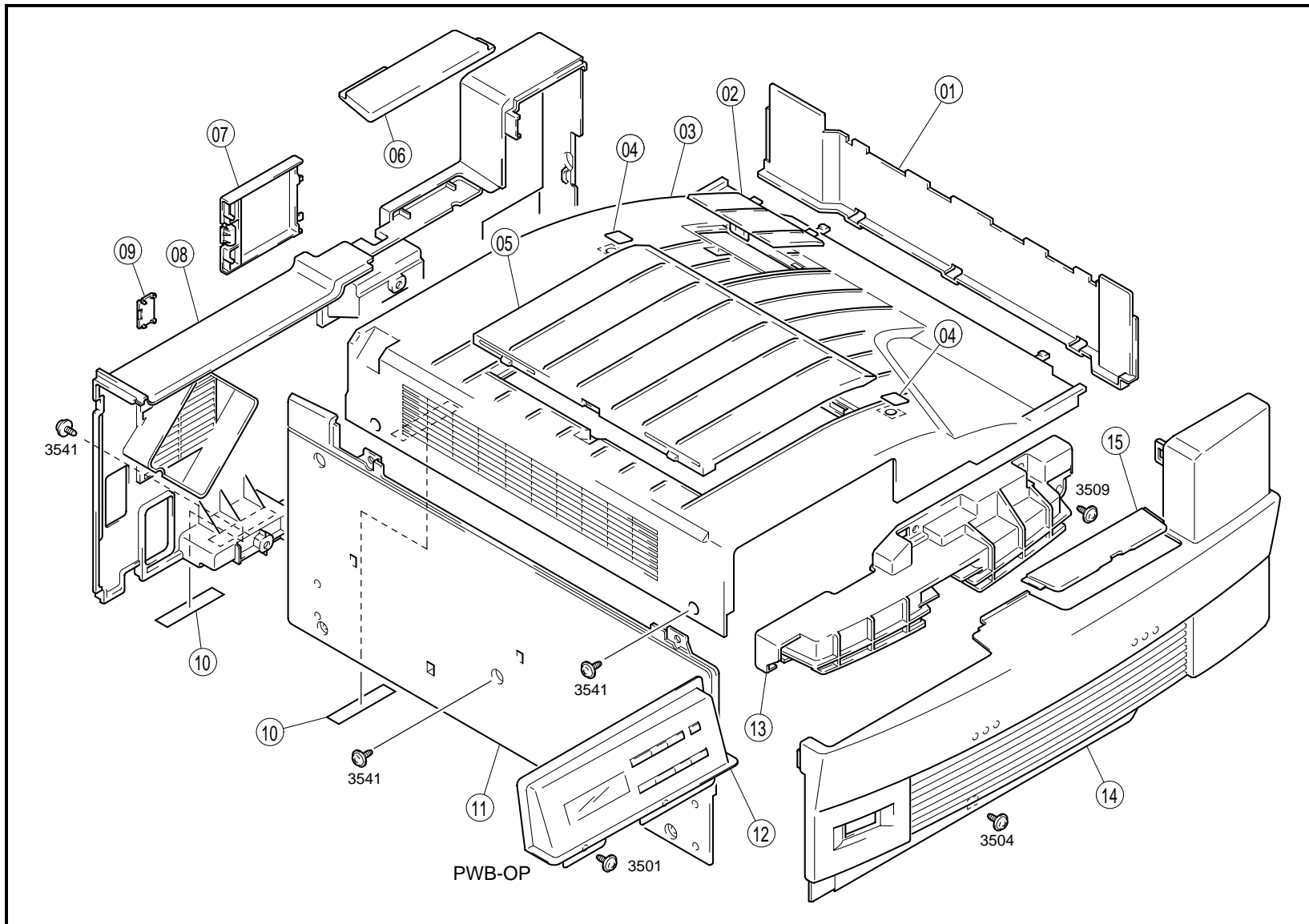

INDEX	PART NO.	PART NAME	QTY	AREA	REMARKS	INDEX	PART NO.	PART NAME	QTY	AREA	REMARKS
01AA	1164-1012-02	COVER	1								
02AA	4108-1020-01	COVER	1								
03AA	4108-1002-04	TOP COVER	1								
04AA	1164-1032-01	SEAL	2								
05AA	4108-1019-01	COVER	1								
06AA	4108-1030-02	COVER	1								
07AA	4108-1006-01	COVER	1								
08AA	4108-1018-05	REAR COVER	1								
09AA	1164-1036-01	COVER	1								
10AA	1164-1031-01	SEAL	2								
11AA	1164-2022-06	RAIL	1								
12AA	4108-0390-02	CONTROL PANEL	1		(PWB-OP)						
13AA	4108-1017-02	HANDLE	1								
14AA	4108-1037-01	FRONT COVER	1		PW25						
14BA	4108-1038-01	FRONT COVER	1		PP25						
15AA	1164-1015-02	COVER	1								

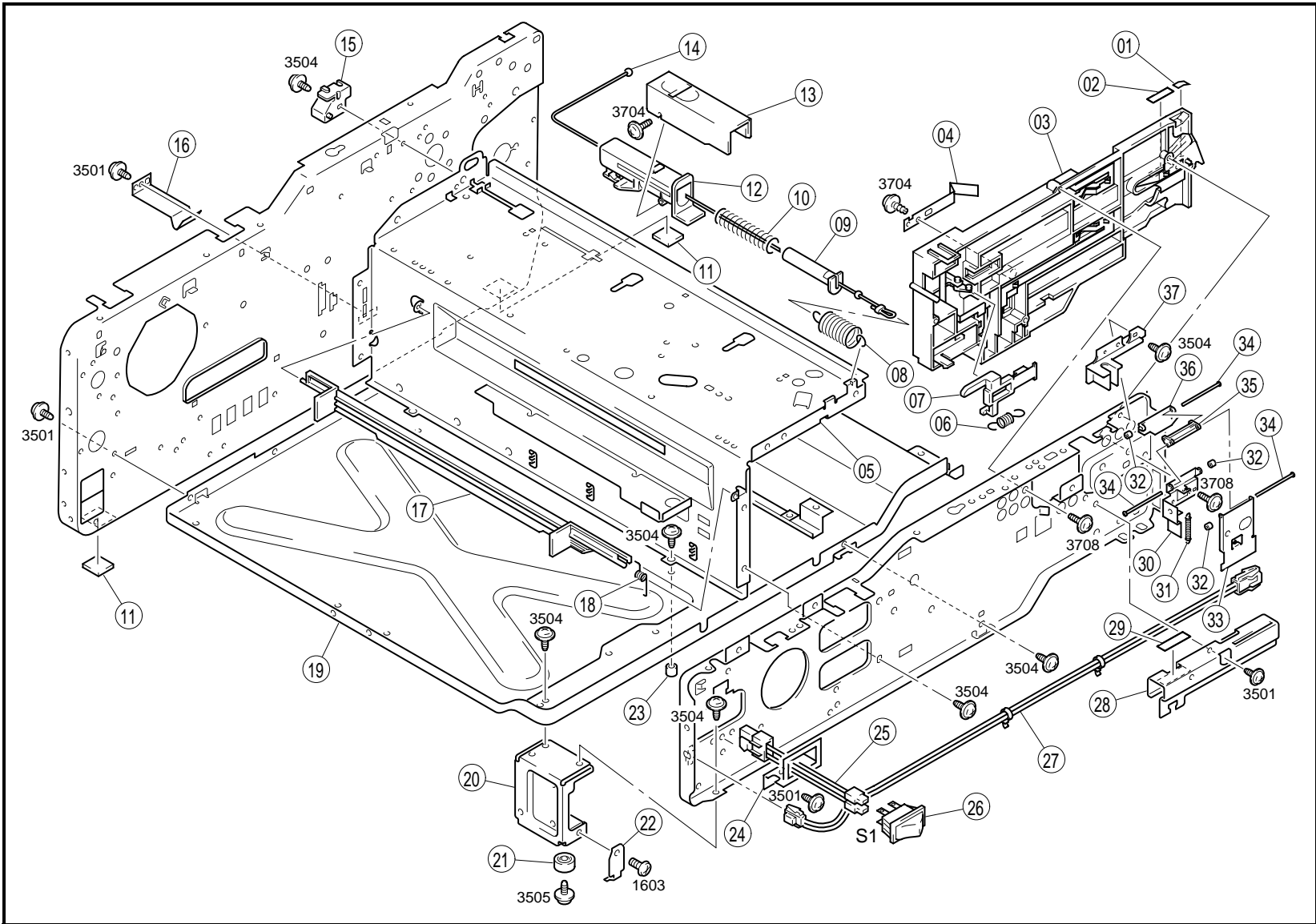

INDEX	PART NO.	PART NAME	QTY	AREA	REMARKS	INDEX	PART NO.	PART NAME	QTY	AREA	REMARKS
01AA	1164-7322-02	LABEL	1								
02AA	1164-7316-01	LABEL	1								
03AA	1164-0751-01	I/C GUIDE ASSY	1								
04AA	1164-2021-02	PLATE SPRING	1								
05AA	1164-2006-06	FRAME	1								
06AA	1164-2039-01	TENSION SPRING	1								
07AA	1164-2038-01	LEVER	1								
08AA	1164-2044-01	TENSION SPRING	1								
09AA	1164-2046-01	FLANGE	1								
10AA	1164-2045-01	PRESSURE SPRING	1								
11AA	4156-3826-01	RUBBER FOOT	2								
12AA	1164-2047-03	FLANGE	1								
13AA	4108-2094-01	COVER	1								
14AA	1164-2043-01	WIRE	1								
15AA	1164-2050-01	GUIDE	1								
16AA	1164-3054-01	PLATE SPRING	1								
17AA	1164-2036-02	SHUTTER	1								
18AA	1164-2037-01	TORSION SPRING	1								
19AA	1164-2001-05	BASE FRAME	1								
20AA	1164-2024-03	FRAME	1								
21AA	0996-3055-01	RUBBER FOOT	1								
22AA	4498-3392-03	HOLDER	1								
23AA	1200-2105-05	COLLAR	1								
24AA	4108-2152-02	BRACKET	1								
25AA	4108-6802-02	HARNESS	1								
26AA	9332-5710-11	SWITCH	1		MAIN SW (S1)						
27AA	4108-6805-01	HARNESS	1								
28AA	1164-2053-02	GUIDE PLATE	1								
29AA	1129-7303-01	LABEL HIGH VOLTAGE	1								
30AA	4108-2095-01	BRACKET	1								
31AA	1400-2143-09	TENSION SPRING	1								
32AA	1200-2105-06	RETAINING RING	3								
33AA	4108-2097-01	LEVER	1								
34AA	1200-5213-04	SHAFT	3								
35AA	4108-2099-01	JOINT	1								
36AA	4108-2096-01	LEVER	1								
37AA	4108-2098-01	GUIDE	1								

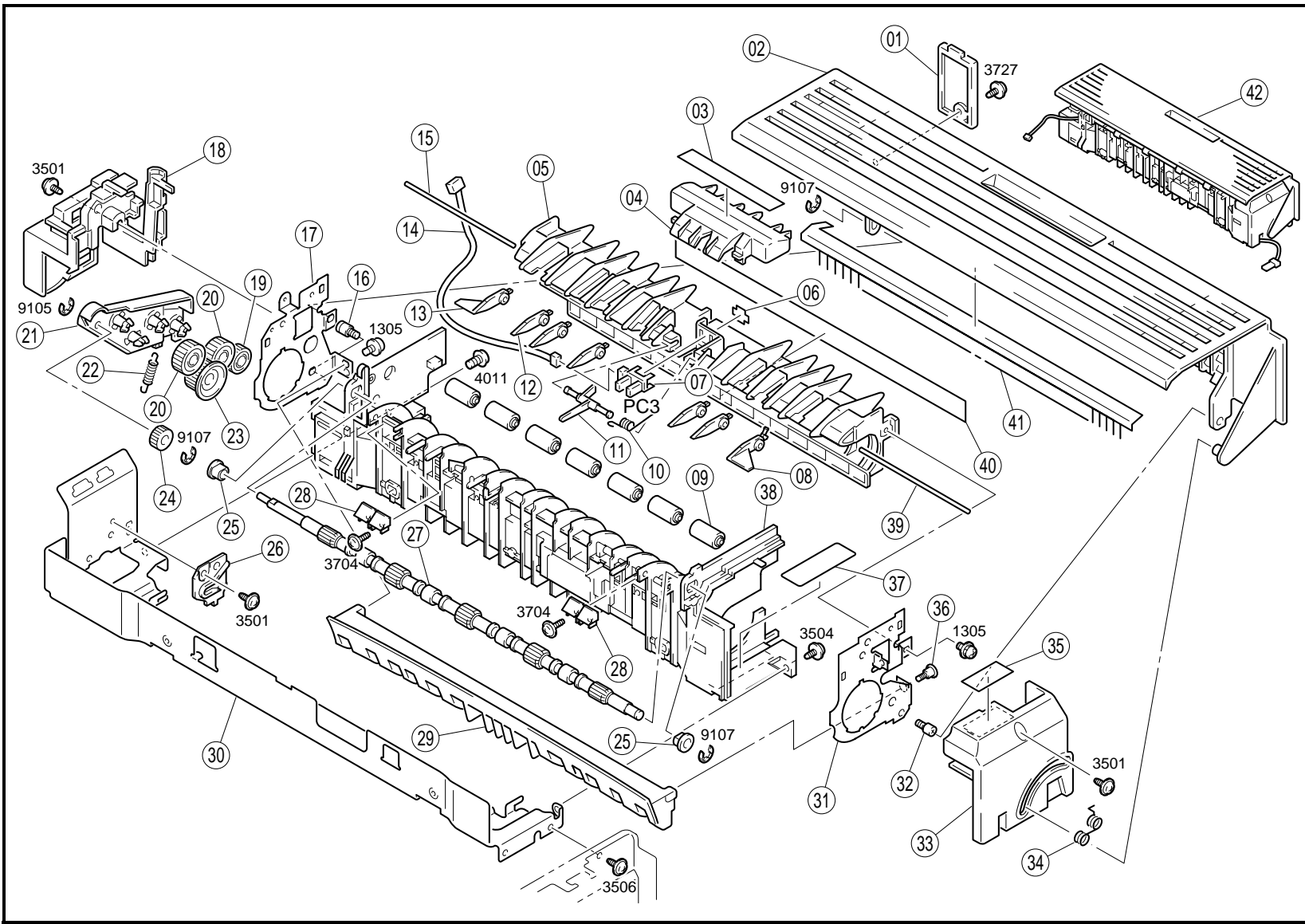

INDEX	PART NO.	PART NAME	QTY	AREA	REMARKS	INDEX	PART NO.	PART NAME	QTY	AREA	REMARKS
01AA	1164-1005-02	COVER	1			42BA	4108-0320-02	FUSING UNIT PP25	1		
02AA	1164-5811-05	COVER	1								
03AA	1164-7310-01	LABEL CAUTION	1								
04AA	1164-5776-03	COVER	1								
05AA	1164-0756-01	GUIDE ASSY	1								
06AA	4470-4024-01	STOPPER	1								
07AA	9335-1510-11	PHOTO INTERRUPTER	1								
		EXIT (PC3)									
08AA	1164-5755-02	GUIDE LEVER	1								
09AA	1164-5762-01	ROLL	7								
10AA	1164-5735-01	TORSION SPRING	1								
11AA	1164-5734-02	ACTUATOR	1								
12AA	1164-5751-02	GUIDE LEVER	5								
13AA	1164-5769-01	GUIDE LEVER	1								
14AA	1164-6805-02	HARNES	1								
15AA	1164-5786-01	SHAFT	1								
16AA	1164-5819-01	SHOULDER SCREW	1								
17AA	1164-5742-04	REAR FRAME	1								
18AA	1164-5731-05	COVER	1								
19AA	0993-3211-01	GEAR 17T	1								
20AA	1164-5809-01	GEAR 22T	2								
21AA	1164-5806-03	LEVER	1								
22AA	1164-5805-03	TENSION SPRING	1								
23AA	1164-5808-02	GEAR 24T	1								
24AA	1164-5807-01	GEAR 14T	1								
25AA	1274-2611-01	BUSHING	2								
26AA	1164-2093-01	HOLDER	1								
27AA	1164-5801-06	ROLLER	1								
28AA	1164-5779-01	GUIDE	2								
29AA	1164-5743-05	GUIDE PLATE-FNT	1								
30AA	4108-0222-07	REINFORCE PLATE	1								
31AA	1164-5741-04	FRONT FRAME	1								
32AA	1164-5816-01	SHOULDER SCREW	1								
33AA	1164-5730-06	COVER	1								
34AA	1164-5815-03	TORSION SPRING	1								
35AA	1164-7328-01	LABEL JAM REMOVAL	1								
36AA	1164-5783-01	SHOULDER SCREW	1								
37AA	1164-5738-01	SEAL	1								
38AA	1164-0752-01	FRAME ASSY	1								
39AA	1164-5785-01	SHAFT	1								
40AA	1164-7311-01	LABEL CAUTION-HOT	1								
41AA	1164-5812-01	NEUTRALIZING BRUSH	1								
42AA	4108-0321-02	FUSING UNIT PW25	1								

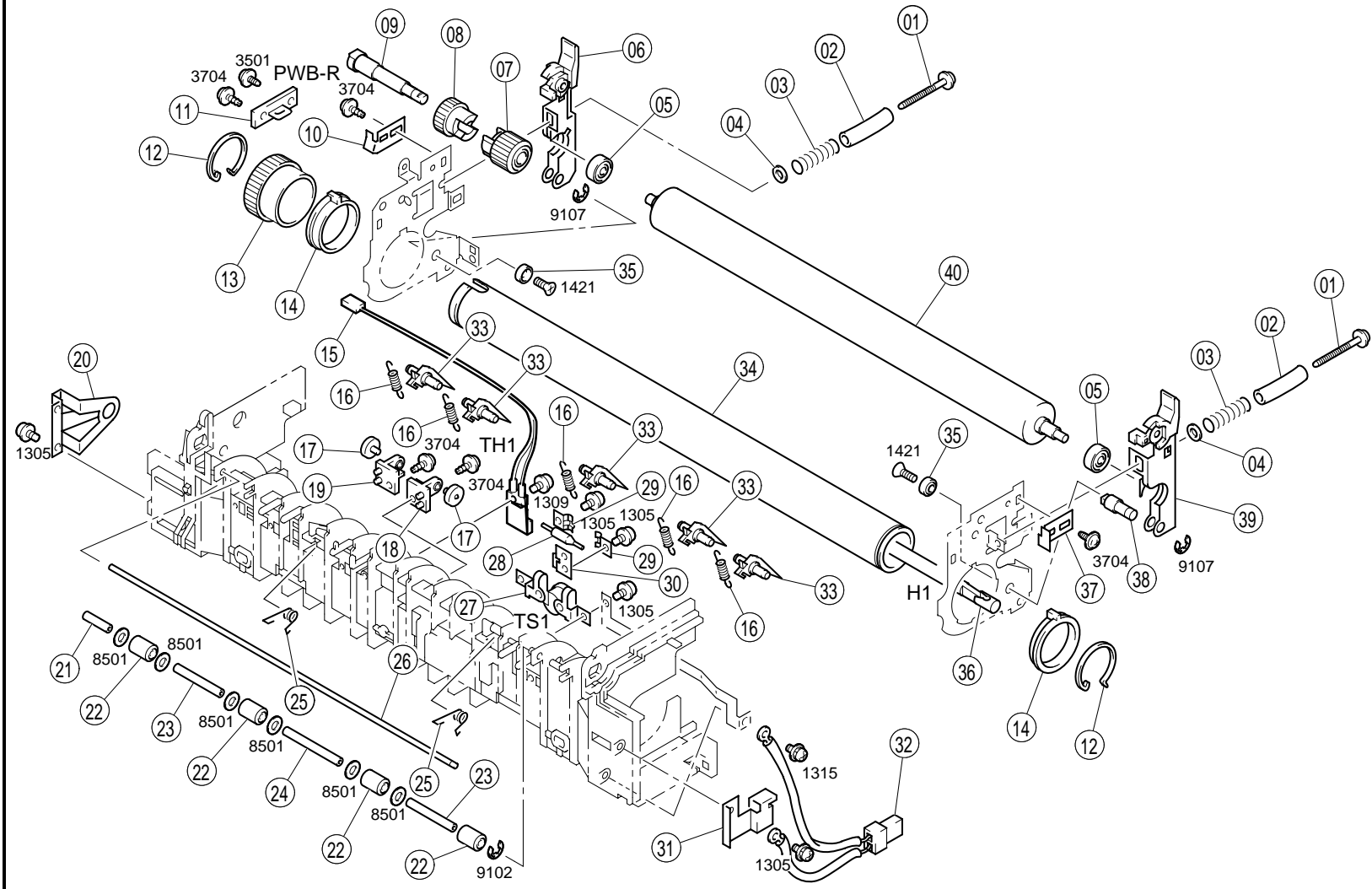

INDEX	PART NO.	PART NAME	QTY	AREA	REMARKS	INDEX	PART NO.	PART NAME	QTY	AREA	REMARKS
01AA	1164-5749-02	SHOULDER SCREW	2								
02AA	1164-5795-01	COLLAR	2								
03AA	1164-5739-02	PRESSURE SPRING	2								
04AA	1164-5782-01	SPACER	2								
05AA	1165-5713-01	BALL BEARING	2								
06AA	1164-0214-04	LEVER	1								
07AA	1164-5758-02	GEAR 20T	1								
08AA	1164-5770-01	GEAR 20T	1								
09AA	1164-5757-02	SHAFT	1								
10AA	1164-5790-03	REGULATING PLATE	1								
11AA	0993-0105-01	PW BOARD-R(NO IC)	1		(PWB-R)						
12AA	1164-5772-01	C-RING	2								
13AA	1164-5709-01	GEAR 39T	1								
14AA	1164-5736-01	BUSHING	2								
15AA	9372-2710-12	THERMISTOR	1		FUSING (TH1)						
16AA	1164-5733-01	PRESSURE SPRING	5								
17AA	1164-5797-02	ROLL	2								
18AA	1164-5796-01	HOLDER	1								
19AA	1164-5798-01	HOLDER	1								
20AA	1164-5737-01	HOLDER	1								
21AA	1164-5831-01	TUBE	1								
22AA	0993-3220-01	ROLL	4								
23AA	1164-5830-01	TUBE	2								
24AA	1164-5829-01	TUBE	1								
25AA	1164-5803-02	TORSION SPRING	2								
26AA	1164-5804-03	SHAFT	1								
27AA	9334-1710-42	THERMOSTAT	1		FUSING (TS1)						
28AA	9346-3810-31	THERMAL FUSE	1								
29AA	1164-5777-01	SUPPORT PLATE	2								
30AA	1164-5778-01	GROUND PLATE	1								
31AA	1164-5744-01	HOLDER	1								
32AA	1164-6804-02	HARNESS	1								
33AA	1164-5732-03	SEPARATOR	5								
34AA	1164-5704-01	FUSING ROLLER	1								
35AA	1164-5719-01	COLLAR	2								
36AA	9352-2711-32	HEATER	1		PW25 (H1)						
36BA	9352-2711-42	HEATER	1		PP25 (H1)						
37AA	1164-5789-03	REGULATING PLATE	1								
38AA	1164-5750-01	SHAFT	1								
39AA	1164-0213-03	LEVER	1								
40AA	1164-5707-01	ROLLER	1								

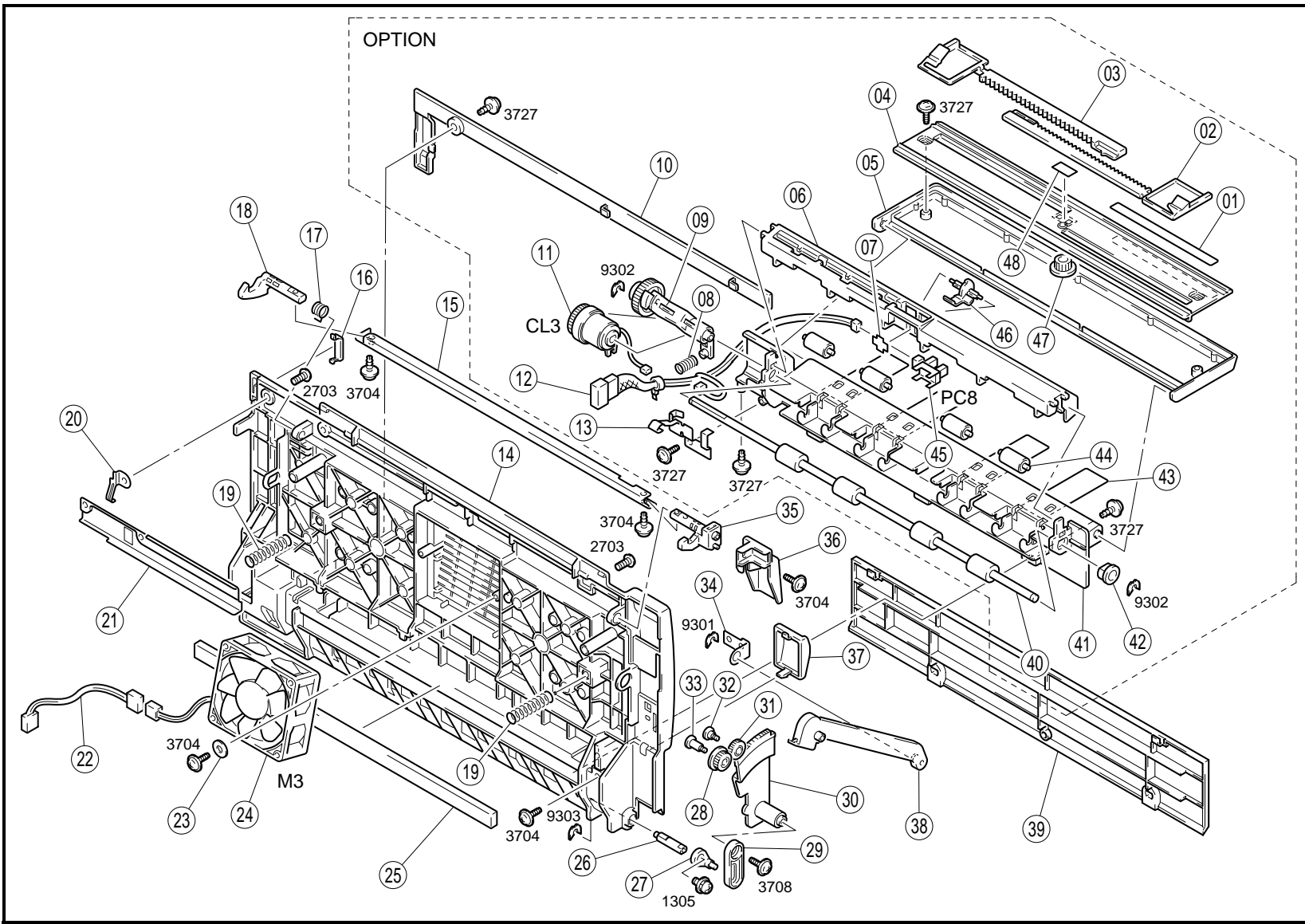

INDEX	PART NO.	PART NAME	QTY	AREA	REMARKS	INDEX	PART NO.	PART NAME	QTY	AREA	REMARKS
*01AA	4603-7473-02	SCALE	1	0400		42AA	1274-2611-01	BUSHING	1		
*01BA	4603-7474-02	SCALE	1	2300		43AA	4603-3218-01	GUIDE BAR	4		
02AA	1164-3203-03	REGULATING PLATE	1			44AA	4603-3207-01	ROLL	4		
03AA	1164-3204-03	REGULATING PLATE	1			45AA	9335-1510-11	PHOTO INTERRUPTER MAN FEED (PC8)	1		
04AA	1164-3221-01	TABLE	1			46AA	4603-3214-01	ACTUATOR	1		
05AA	1164-3222-02	COVER	1			47AA	4603-3205-01	GEAR 12T	1		
06AA	4603-3202-01	COVER	1			48AA	4603-7477-01	LABEL	1		
07AA	4470-4024-01	STOPPER	1								
08AA	4603-3211-01	PRESSURE SPRING	1								
09AA	4603-0751-01	LEVER ASSY	1								
10AA	1164-3220-02	COVER	1								
11AA	9322-1710-21	CLUTCH MAN FEED (CL3)	1								
12AA	4603-6801-04	HARNES	1								
13AA	4603-3216-04	GROUND PLATE	1								
14AA	1164-0757-01	COVER ASSY	1								
15AA	1164-2014-03	LOCK PLATE	1								
16AA	1164-1033-01	COVER	1								
17AA	1164-2013-02	TORSION SPRING	1								
18AA	1164-2011-03	HOOK	1								
19AA	1164-3518-01	PRESSURE SPRING	2								
20AA	1164-2071-02	GROUND PLATE	1								
21AA	1164-2067-03	BRACKET	1								
22AA	1164-6816-01	HARNES	1								
23AA	1200-1411-01	WASHER	2								
24AA	9313-1710-51	FAN MOTOR COOLING (M3)	1								
25AA	1164-3526-01	CUSHION	1								
26AA	1164-2015-01	SHAFT	1								
27AA	1164-2007-01	JOINT	1								
28AA	1164-2027-02	GEAR 14T	1								
29AA	1164-2008-01	LEVER	1								
30AA	1164-2009-03	LEVER	1								
31AA	1164-2026-01	GEAR 14T	1								
32AA	1164-2028-01	SHOULDER SCREW	1								
33AA	1164-2084-01	SHOULDER SCREW	1								
34AA	1164-2054-01	BRACKET	1								
35AA	1164-2017-04	HOOK	1								
36AA	1164-2012-02	LOCK RELEASE LEVER	1								
37AA	1164-1034-01	COVER	1								
38AA	1164-2052-02	LEVER	1								
39AA	4108-1003-01	COVER	1								
40AA	4603-3206-01	ROLLER	1								
41AA	1164-3201-05	GUIDE	1								

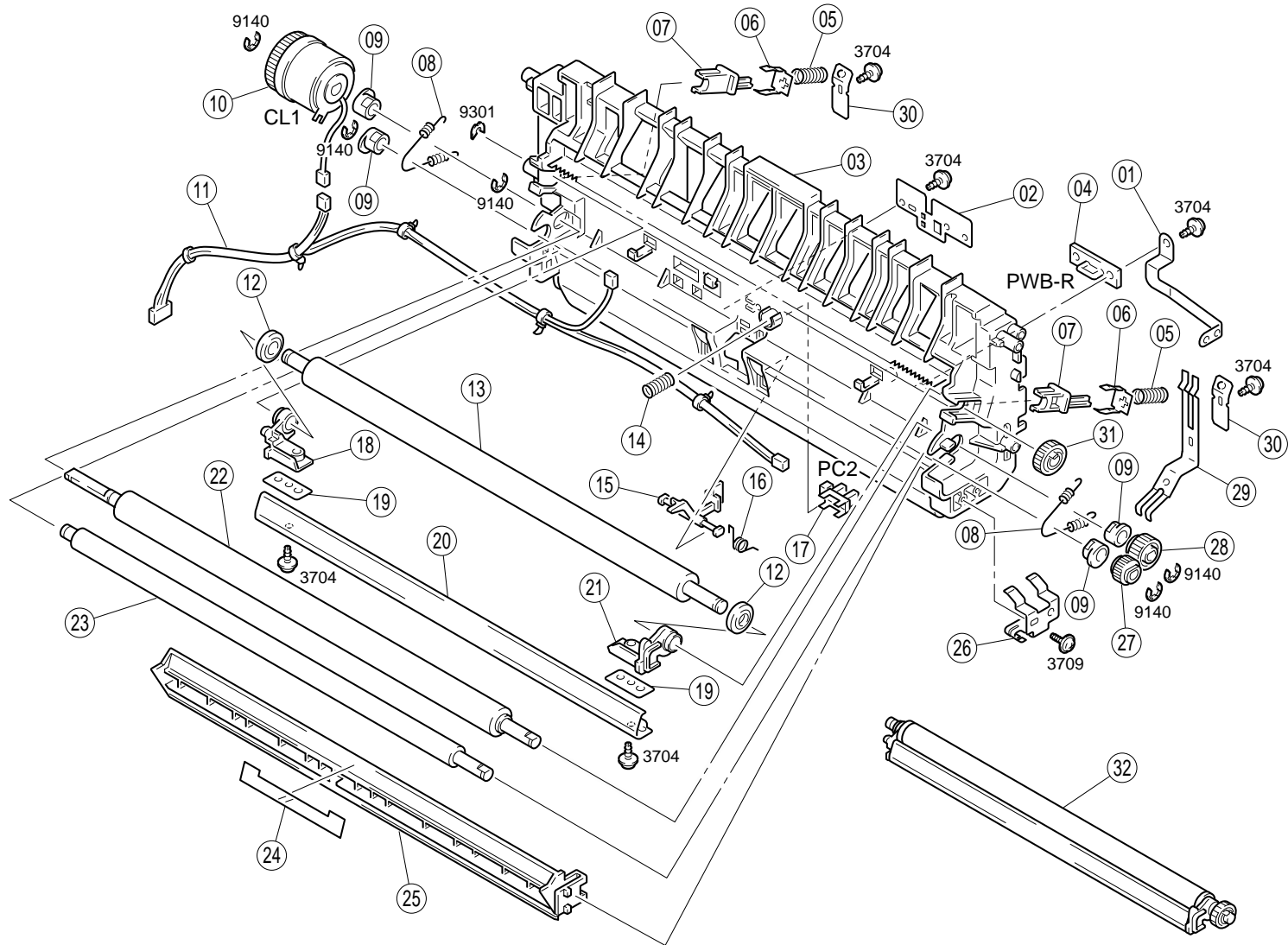

INDEX	PART NO.	PART NAME	QTY	AREA	REMARKS	INDEX	PART NO.	PART NAME	QTY	AREA	REMARKS
01AA	1164-4220-01	TERMINAL	1								
02AA	1164-3529-01	BRACKET	1								
03AA	1164-0753-01	HOLDER ASSY	1								
04AA	1164-0109-01	PW BOARD-R (PWB-R)	1								
05AA	1164-4207-01	PRESSURE SPRING	2								
06AA	1164-4222-01	PLATE SPRING	2								
07AA	1164-4206-02	BUSHING	2								
08AA	1164-3513-01	TENSION SPRING	2								
09AA	1164-3509-01	BUSHING	4								
10AA	9322-1710-42	CLUTCH TIMING (CL1)	1								
11AA	1164-6806-03	HARNESS	1								
12AA	1164-4212-01	COLLAR	2								
13AA	1164-4201-01	ROLLER	1								
14AA	1164-4213-01	PRESSURE SPRING	1								
15AA	1164-3504-03	ACTUATOR	1								
16AA	1164-3527-02	TORSION SPRING	1								
17AA	9335-1510-11	PHOTO INTERRUPTER TIMING (PC2)	1								
18AA	1164-4205-04	HOLDER	1								
19AA	1164-4223-02	POLYESTER FILM	4								
20AA	1164-4210-02	GUIDE PLATE	1								
21AA	1164-4204-03	HOLDER	1								
22AA	1164-3505-01	CONVEYOR ROLLER	1								
23AA	1164-3507-01	CONVEYOR ROLLER	1								
24AA	1164-3530-01	POLYESTER FILM	1								
25AA	1164-3503-04	GUIDE BAR	1								
26AA	1164-3514-02	GROUND PLATE	1								
27AA	1164-3515-01	GEAR 13T	1								
28AA	1164-3508-01	GEAR 18T	1								
29AA	1164-4219-02	TERMINAL	1								
30AA	1164-4209-02	GROUND PLATE	2								
31AA	1164-4203-02	GEAR 18T	1								
32AA	1164-0335-01	TRANSFER ROLLER UNIT	1								

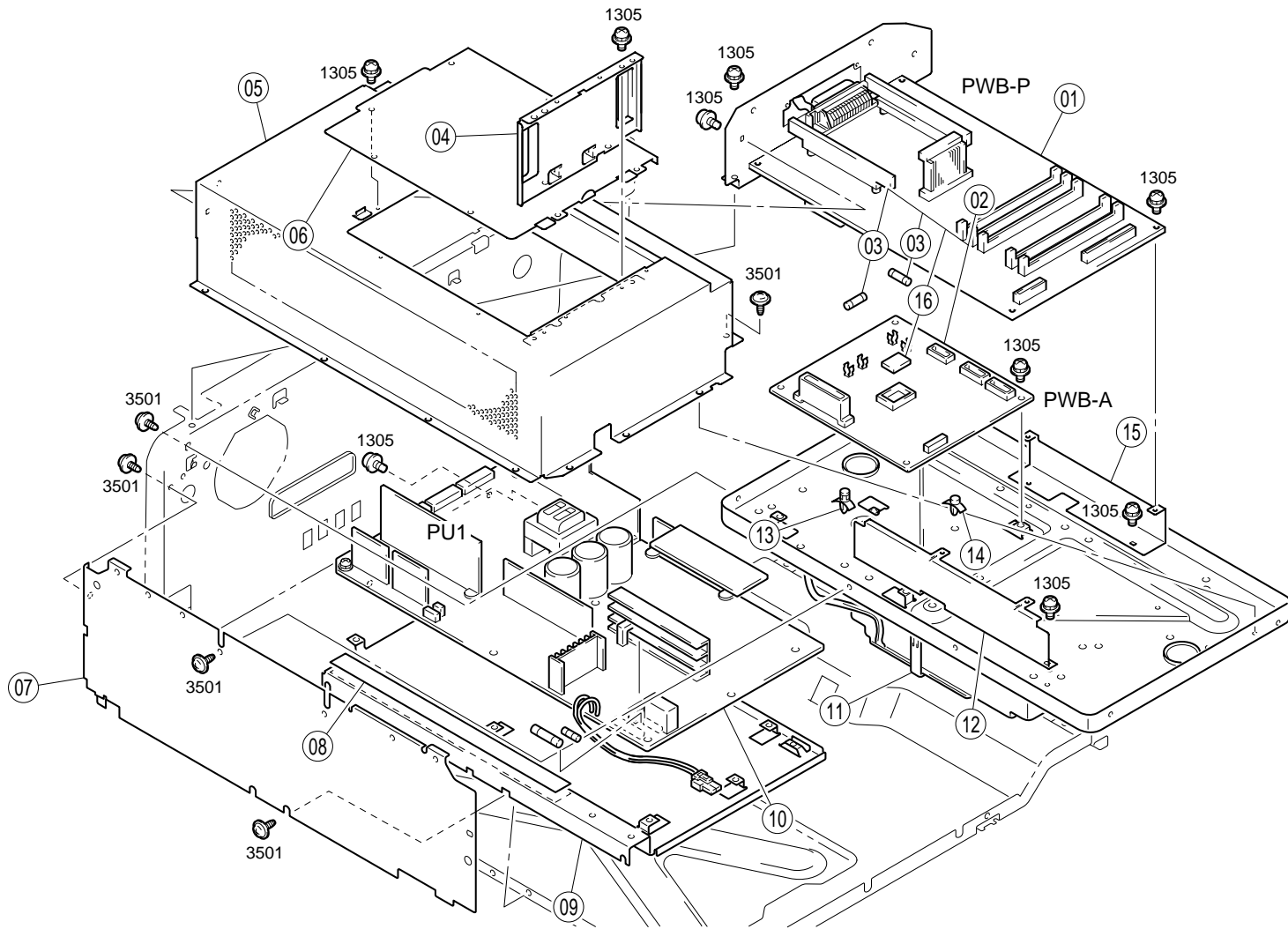

INDEX	PART NO.	PART NAME	QTY	AREA	REMARKS	INDEX	PART NO.	PART NAME	QTY	AREA	REMARKS
01AA	4108-0112-03	PW BOARD-P (PWB-P)	1								
02AA	4108-0101-18	PW BOARD-A MAIN (PWB-A)	1								
03AA	9346-3710-21	FUSE 3A	2								
04AA	4108-2193-01	BRACKET	1								
05AA	4108-2190-02	COVER	1								
06AA	4108-2200-01	COVER	1								
07AA	1164-2058-05	REINFOCE PLATE	1								
08AA	4108-7319-01	LABEL CAUTION	1								
09AA	4108-2164-02	BRACKET	1								
10AA	9325-2810-12	POWER SUPPLY PW25 (PU1)	1								
10BA	9325-2710-25	POWER SUPPLY PP25 (PU1)	1								
11AA	1164-0532-01	P/H ASSY	1								
12AA	4108-2197-01	BRACKET	1								
13AA	9384-1621-21	PWB SUPPORT 6.4H	2								
14AA	9384-1610-11	PWB SUPPORT	1								
15AA	4108-2196-01	BRACKET	1								
16AA	4108-6601-03	IC	1								

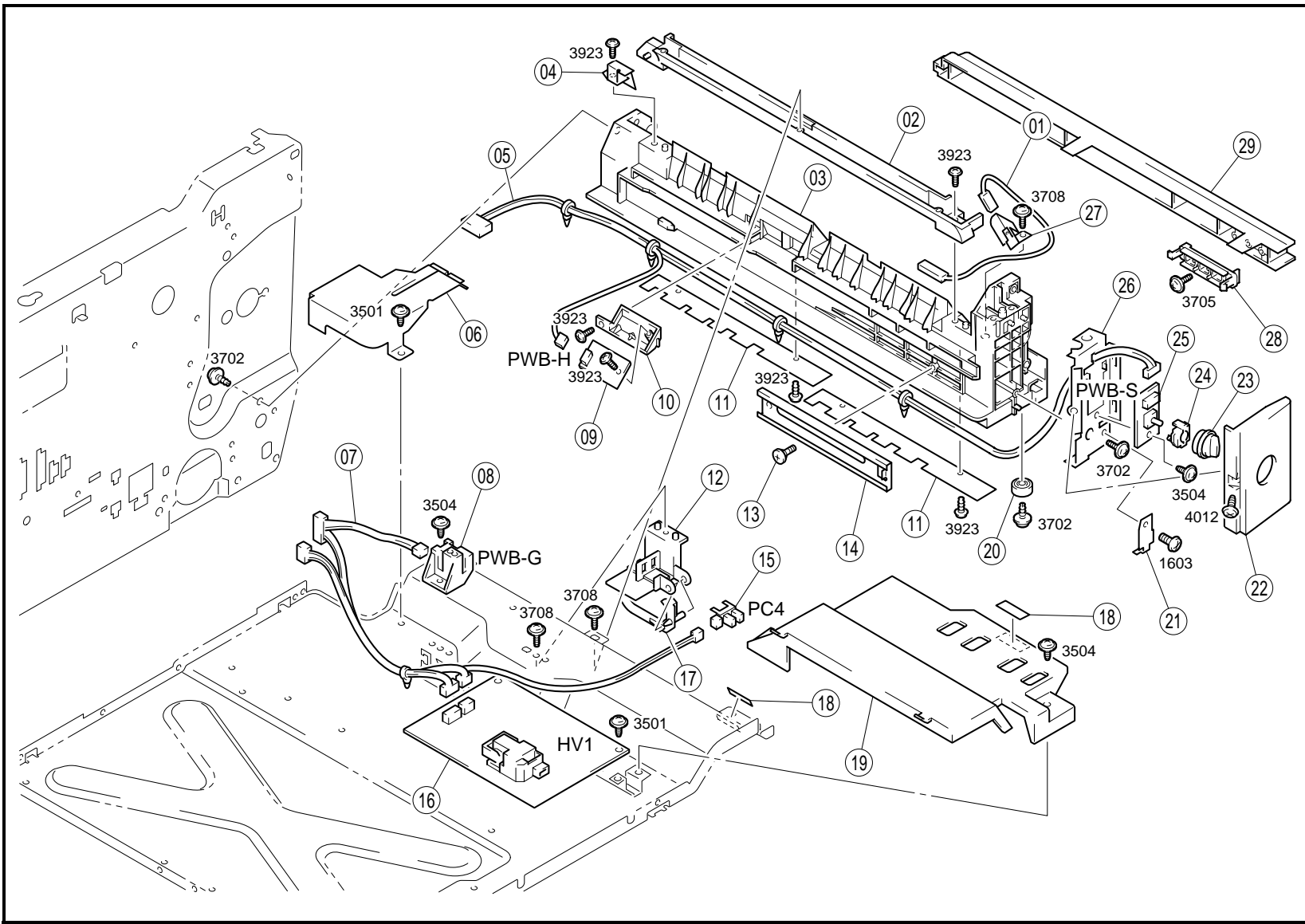

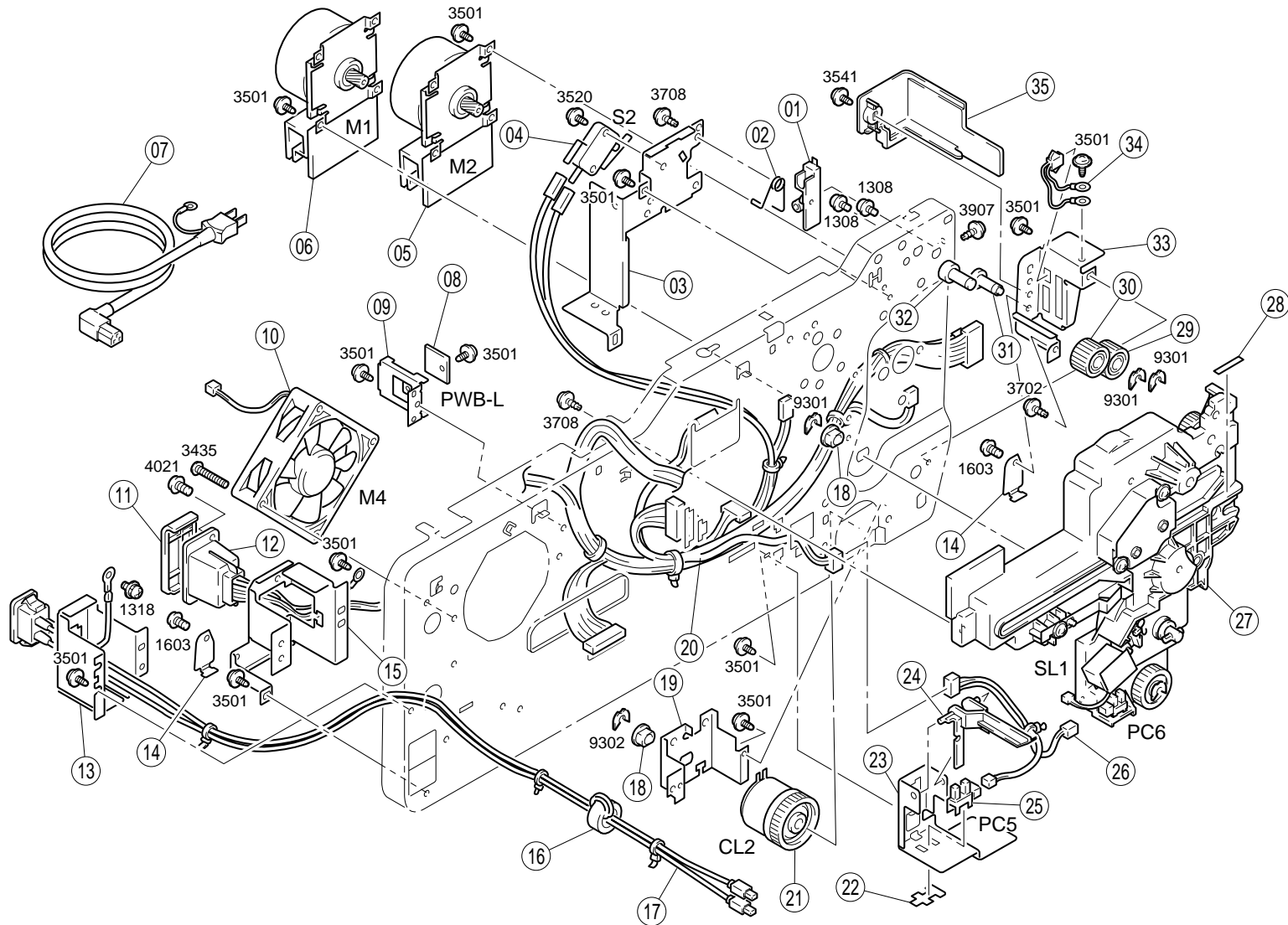

INDEX	PART NO.	PART NAME	QTY	AREA	REMARKS	INDEX	PART NO.	PART NAME	QTY	AREA	REMARKS
01AA	1164-6808-01	HARNES	1								
02AA	1164-3521-04	GUIDE BAR	1								
03AA	1164-2023-04	RAIL	1								
04AA	1164-2157-02	GROUND PLATE	1								
05AA	4108-6803-02	HARNES	1								
06AA	1164-2079-01	BRACKET	1								
07AA	1164-6807-02	HARNES	1								
08AA	1164-0107-04	PW BOARD-G	EMPTY	(PWB-G)	1						
09AA	1164-0108-02	PW BOARD-H	PAPER	(PWB-H)	1						
10AA	1164-2080-01	HOLDER	1								
11AA	1164-2070-01	COVER	2								
12AA	1164-3026-02	COVER	1								
13AA	1164-3053-01	SHOULDER SCREW	1								
14AA	1164-3051-02	RAIL	1								
15AA	9335-1510-11	PHOTO INTERRUPTER	EMPTY	(PC4)	1						
16AA	9325-1710-13	PWB-HV		(HV)	1						
17AA	1164-3027-01	ACTUATOR	1								
18AA	1129-7303-01	LABEL HIGH VOLTAGE	2								
19AA	1164-0754-01	COVER ASSY	1								
20AA	0996-3055-01	RUBBER FOOT	1								
21AA	4498-3392-03	HOLDER	1								
22AA	4108-3075-02	COVER	1								
23AA	4108-3078-01	LEVER	1								
24AA	4108-3079-01	HOLDER	1								
25AA	4108-0105-01	PW BOARD-S	SIZE	(PWB-S)	1						
26AA	4108-3077-02	BRACKET	1								
27AA	1164-2155-01	TERMINAL	1								
28AA	4108-3414-02	LEVER	1								
29AA	1164-3302-02	COVER	1								

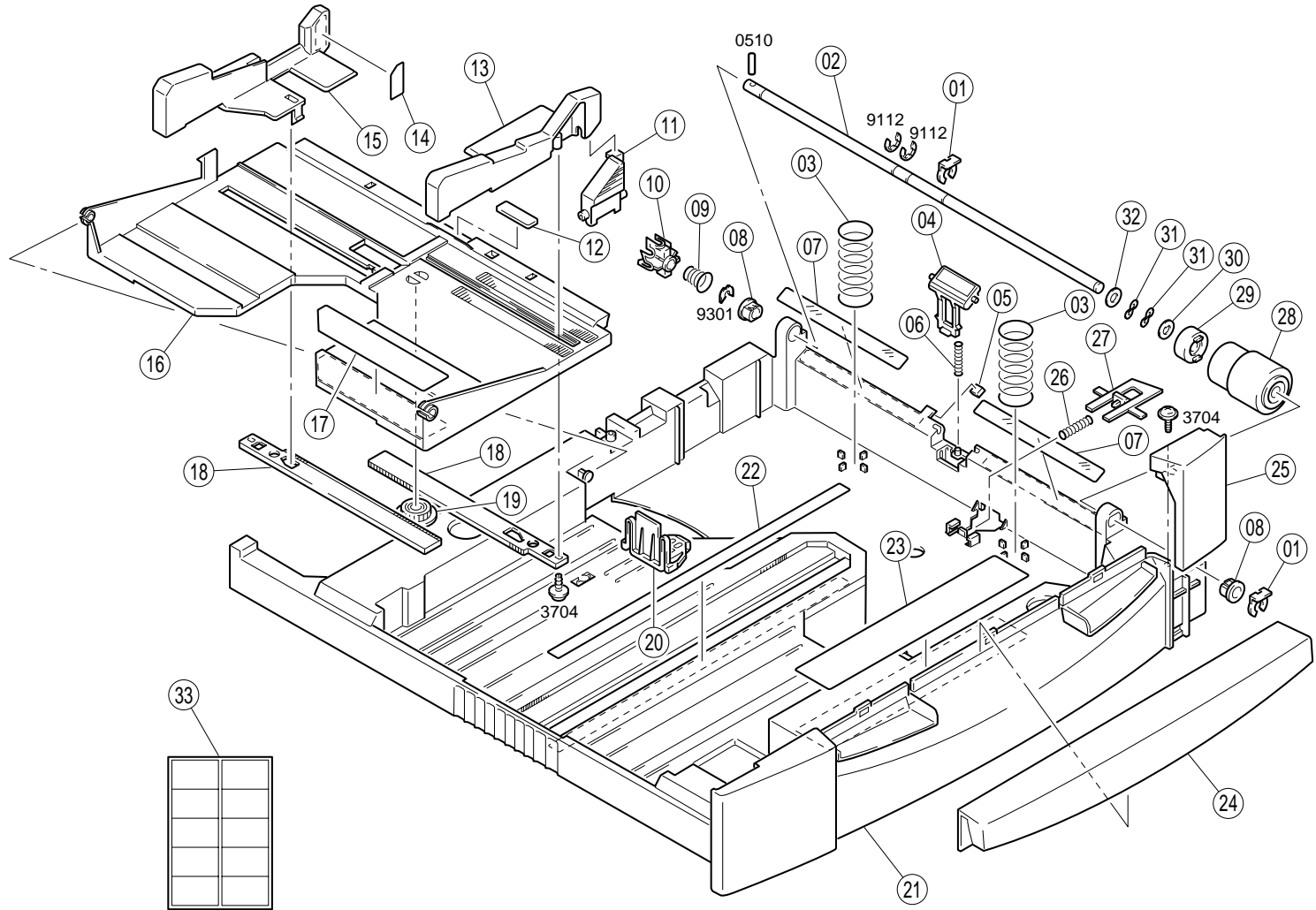

INDEX	PART NO.	PART NAME	QTY	AREA	REMARKS	INDEX	PART NO.	PART NAME	QTY	AREA	REMARKS
01AA	1164-2051-01	GUIDE	1								
02AA	1164-2049-02	TORSION SPRING	1								
03AA	1164-2116-02	BRACKET	1								
04AA	9331-2710-11	MICRO SWITCH	DOOR SIDE	(S2)	1						
05AA	9314-2710-82	PWB-MOTOR	TRANS	(M2)	1						
06AA	9314-2710-72	PWB-MOTOR	I/C	(M1)	1						
07AA	9381-4610-31	POWER CORD	PW25		1						
07BA	9381-4310-71	POWER CORD	OPTION		1						
08AA	1164-0112-01	PW BOARD-L	CPM	(PWB-L)	1						
09AA	1164-2089-01	BRACKET			1						
10AA	9313-1710-61	FAN MOTOR	COOLING	(M4)	1						
11AA	9384-2310-41	COVER			1						
12AA	1164-6811-01	HARNESS			1						
13AA	1164-2165-02	BRACKET			1						
14AA	4498-3392-03	HOLDER			2						
15AA	1164-2123-01	BRACKET			1						
16AA	9326-1510-41	FERRITE CORE			1						
17AA	4108-6801-03	HARNESS			1						
18AA	1200-3231-05	BUSHING			2						
19AA	1164-2535-02	BRACKET			1						
20AA	4108-6804-05	HARNESS			1						
21AA	9322-1710-51	CLUTCH	VERT	(CL2)	1						
22AA	1149-3444-01	COVER			1						
23AA	1164-3024-03	BRACKET			1						
24AA	1164-3023-01	LEVER			1						
25AA	9335-1510-11	PHOTO INTERRUPTER	NEER EMP	(PC5)	1						
26AA	1164-6809-01	HARNESS			1						
27AA	1164-0160-05	DRIVE UNIT			1						
28AA	1164-7323-01	LABEL			1						
29AA	1164-2517-01	GEAR 20T			1						
30AA	1164-2513-01	GEAR 18T			1						
31AA	1164-2530-01	SHAFT			1						
32AA	1164-2527-01	SHAFT			1						
33AA	1164-2041-02	BRACKET			1						
34AA	1164-6814-01	HARNESS			1						
35AA	1164-1007-01	COVER			1						

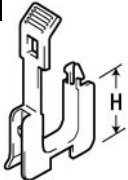
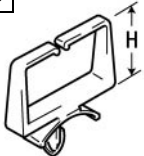
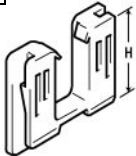

INDEX	PART NO.	PART NAME	QTY	AREA	REMARKS	INDEX	PART NO.	PART NAME	QTY	AREA	REMARKS
01AA	1164-3065-01	STOPPER RING	2								
02AA	1164-3002-03	SHAFT	1								
03AA	1164-3047-02	PRESSURE SPRING	2								
04AA	1164-0755-01	SEPARATOR	1								
05AA	1164-3009-01	CLEANING PAD	1								
06AA	1164-3008-03	PRESSURE SPRING	1								
07AA	1164-3046-01	POLYESTER FILM	2								
08AA	1164-3003-01	BUSHING	2								
09AA	1164-3005-02	PRESSURE SPRING	1								
10AA	1164-3004-02	JOINT	1								
11AA	1164-3050-04	LOCK LEVER	1								
12AA	1164-3064-01	FRICITION SHEET	1								
13AA	1164-3043-02	REGULATING PLATE	1								
14AA	1164-7343-02	LABEL MAX LEVEL	1								
15AA	1164-3044-03	REGULATING PLATE	1								
16AA	1164-3042-03	LIFTING PLATE	1								
17AA	4108-7350-01	WIDTH SCALE	1								
18AA	1164-3049-02	RACK GEAR	2								
19AA	1164-3045-01	GEAR 20T	1								
20AA	1164-3048-02	REGULATING PLATE	1								
21AA	1164-3041-05	CASSETTE BODY	1								
22AA	4108-7351-01	LENGTH SCALE	1								
23AA	4108-7342-02	LABEL PAPER LOADING	1								
24AA	1164-3055-02	HANDLE	1								
25AA	4108-3076-03	COVER	1								
26AA	1164-3062-01	PRESSURE SPRING	1								
27AA	1164-3061-01	LOCK LEVER	1								
28AA	1164-3001-01	ROLL	1								
29AA	1164-3063-04	WEIGHT	1								
30AA	1164-3066-01	WASHER	1								
31AA	1500-2660-13	WAVE WASHER	2								
32AA	1200-1462-01	WASHER	1								
33AA	4108-7348-01	LABEL PAPER SIZE	1								

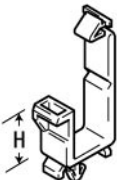
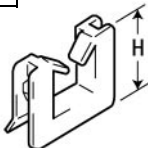
<p>01</p> 	<p>06</p> 						
<p>02</p> 	<p>07</p> 						
<p>03</p> 							
<p>04</p> 							
<p>05</p> 							

INDEX	PART NO.	PART NAME	QTY	AREA	REMARKS	INDEX	PART NO.	PART NAME	QTY	AREA	REMARKS
01AA	9384-1110-61	WIRING SADDLE 21.5H	2								
01BA	9384-1211-01	WIRING SADDLE 19.2H	8								
01CA	9384-1310-11	WIRING SADDLE 5.2H	5								
02AA	9384-1310-81	WIRING SADDLE 6.4H	17								
03AA	9384-1311-01	WIRING SADDLE 27H	6								
04AA	9384-1311-11	CABLE TIE 104L	1								
05AA	9384-2010-21	EDGE COVER 8.5H	9								
06AA	9384-2010-31	EDGE COVER 15.4H	5								
06BA	9384-2010-41	EDGE COVER 25.0H	2								
07AA	9384-2600-11	EDGE COVER 26H	2								



Copyright
1998 MINOLTA Co., Ltd.

4108-7995-21 98092220